

Quick Start Guide

TCM_E80_Q_EN_170116_E002



TRICOR[®] Coriolis Mass Flow Meter

Manual-Version

TCM_E80_Q_EN_170116_E002

SW-Version

This manual is valid for

Main SW: Mv3.40 and higher

Display SW: Dv3.40 and higher

This Quick Start Guide contains the essential instructions to install, wire and operate your new TRICOR Mass Flow Meter that has been factory calibrated and configured to your specific application. If the configuration of the transmitter requires changes, download complete instruction manual from the TRICOR website www.tricorflow.com.

Additional to this manual the full size manual contains:

- Dimensional drawings for the mechanical installation
- Circuit diagrams for the electrical installation
- A complete description of the manual control including all submenus
- A description of the remote control via interface
- Chapters for maintenance, calibration and service
- The complete technical data

1. Features

The TRICOR Mass Flow Meter, based on the Coriolis principle, have many advantages compared to other Flow Meter principles.

- No moving parts
- High accuracy (0.1%)
- Simultaneous measuring of mass flow, density and temperature
- Calculation of volume flow as well as mass and volume total
- Flushable

The TRICOR Mass Flow Meters are available as compact versions with onsite display and as meter with remote display for wall or panel mount. All versions are available as standard version as well as Ex certified for hazardous locations (ATEX, IECEx, cCSAus).

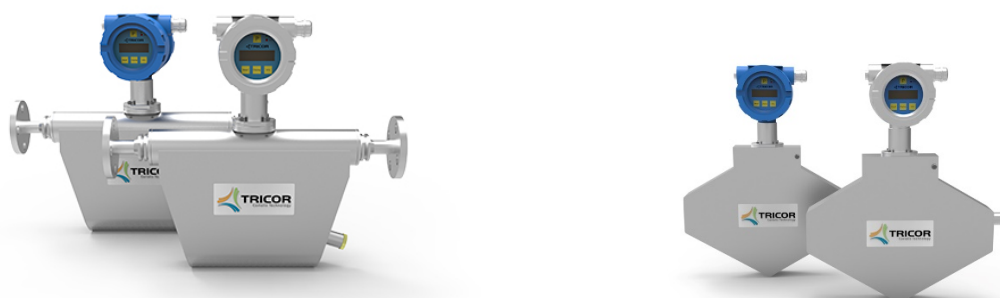

Fig. 1: Compact versions



Fig. 2: Separate version with panel mount (left) or wall mount (right) electronics

2. Sensor Mounting

The horizontal installation is the recommended installation. If the medium might contain solid particles, mount the meter as shown in position "A", in all other cases as shown in position "B". Install the meter to a solid, non-vibrating surface as close to the meter as possible. With the TCM 0325 through TCM 3100 this could be done via the optional mounting threads or with the TCMH 0450 via the mounting holes.

TCMH Mass Flow Meters for high pressure applications (>400 bar) should not be mounted in vertical position. The diamond shaped TCM 0325 through TCM 3100 should not be mounted vertically except you are sure that the medium contains neither gas bubbles nor solid particles. All other meters can be mounted vertically. This would be the recommended position, if the medium might contain gas bubbles and solid particles.

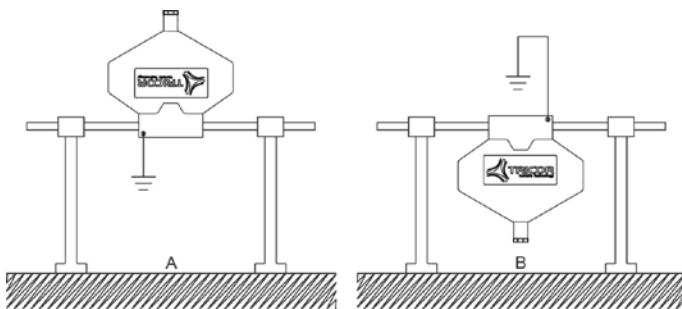

Fig. 3: Recommended horizontal Installation

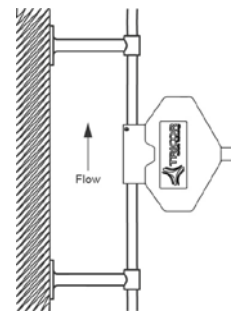

Fig. 4: Vertical Installation

It is recommended to mount the meter in an upstream position for avoiding that it runs empty during operation. Fix the meter to a solid, non-vibrating surface as close to the meter as possible. If no non-vibrating surface is available, vibration dampers might be recommended.

The meters must not be mounted at the highest point of the tubing (A), if gas bubbles are to be expected, or at the lowest point (B), if solid particles are to be expected, as in both cases also the right orientation might not help.

Also the meters must not be mounted in a drop line near the open end (C), as in that case the meter might run empty.

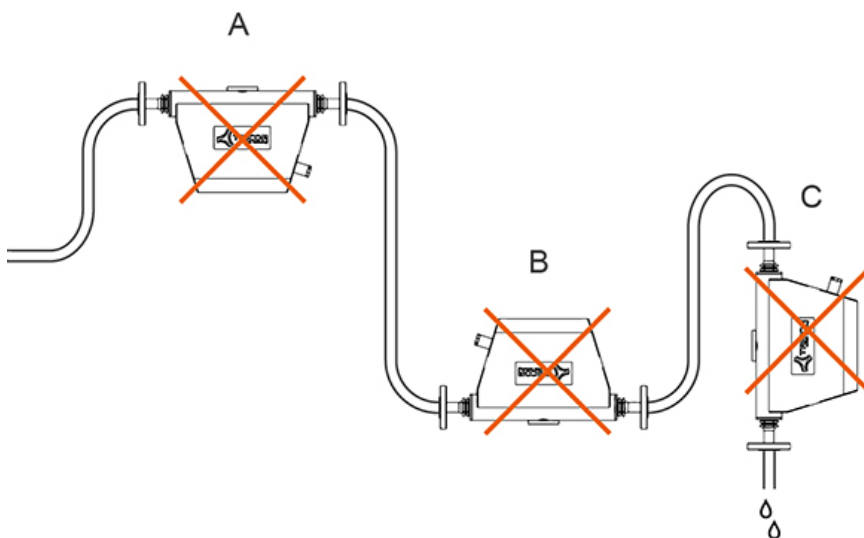

Fig. 5: Critical Installations

3. Transmitter Mounting

TCE 8***-W

The wall mount TCE is to be mounted on the wall with 2 screws with 5 mm diameter, about 40 mm apart.

TCE 8***-L, TCE 8***-S

The housing requires an opening in the panel of 92 mm x 92 mm (TCE 8***-S) or 138 mm x 92 mm (TCE 8***-L) at a maximum panel thickness of 2 mm. Push the TCE 8*** into the opening. The springs will fix the unit automatically.

For removing the TCE 8*** press the springs towards the housing via a screwdriver.

4. Electrical Installation

Make sure that the TCM is properly mounted and the process input and output are connected before making the electrical connections. The TCM must be grounded. The TCE requires a regulated DC power supply of 24 V $\pm 20\%$ or a mains voltage of 100 to 240 V AC, depending on the version.

The digital inputs and outputs are referred to GND and to the ground potential of the DC supply (= negative pole). The AC supply terminals are electrically isolated from all inputs and outputs. The ground potential GND is connected to protective ground via a 1 k Ω resistor. The resistor will thermally withstand a potential difference of up to 30 V between PE and GND but for proper operation this difference should be limited to 5 V.

To connect the TCE, shielded cables must be used. The shield should be connected to the case. If the TCM is installed in bigger systems and the shield must not present a DC connection for avoiding high ground loop currents, make the ground connection of the shield via a capacitor of e.g. 100 nF.

4.1. Connecting the cable to the TCM

With the remote version the TCE and TCM must be connected before making the other electrical installations. If no TCM is connected to the TCE, the TCE will only show an error message after power on. For connecting TCE and TCM, only the supplied special cable must be used. For best accuracy the maximum cable length is limited to 20 m.

Open the junction box of the TCM. Feed the cable from the TCE into the cable gland of the TCM and connect the single wires. The colors in the table are for the standard cable. Adjust the position of the cable in the cable glands and close the cable gland. This wiring table is valid only for Junction boxes (code S***-AZZS or S***-HZZS) when temperature is below 100°C (212°F). For junction boxes applicable for higher temperatures (H***-HZZS or T***-HZZS) please check the manual available in the download area www.tricorflow.com.

| Terminal | Signal | Color | Wire number |
|----------|-------------------|--------------|-------------|
| 1 | Driver + | Grey | 1 |
| 2 | Driver - | Pink | 2 |
| 3 | Sensor A + | Blue | 3 |
| 4 | Sensor A - | Red | 4 |
| 5 | Sensor B + | White | 5 |
| 6 | Sensor B - | Brown | 6 |
| 7 | Pt1000 + | Green | 7 |
| 8 | Pt1000 - | Yellow | 8 |
| PE | Protective ground | Yellow/green | |

Close the top cover of the junction box and fix it with the screw.

4.2. Connecting the cable to the TCE 8***-L-* or TCE 8***-S-*

Connect the D-Sub connector of the cable to the connector “sensor” on the back side of the housing. Fasten the fixing screws of the D-SUB connector properly.

4.3. Power Supply and Grounding

4.3.1. 24V DC Power Supply

The TCE requires a regulated DC power supply of 24 V \pm 20%.

The power supply input of the TCE is protected by a fuse. As a protection against fire in case of a short in the supply cable, the output of the power supply must be equipped with a fuse with a rating not higher than the current carrying capacity of the cable used.

For connecting the TCE use shielded cables. If several cables are used, each cable should be shielded properly. Connect the ground of your power supply to terminal 51 and the 24 V to terminal 50.

The ground terminals 8 and 51 are internally connected together.

Ground and protective ground are internally connected via a 1 k Ω resistor. The resistor will thermally withstand a potential difference of up to 30 V between PE and GND but for proper operation this difference should be limited to 5 V.

4.3.2. 100...240V AC Mains Supply

The AC version of the TCE requires a nominal power supply of 100...240 V AC and operates over a range of 90...264 V AC.

The power supply input of the TCE is protected by a 1 A slow blow fuse. As a protection against fire in case of a short in the supply cable, the output of the power supply must be equipped with a fuse with a rating not higher than the current carrying capacity of the cable used.

For the mains powered TCE a good connection of PE is mandatory. The cross section of the PE cable should be at least equivalent to the cross section of the supply cable or to 1 mm², whichever is higher.

Connect the supply to terminal 91 (neutral) and 90 (phase).

The ground terminal 8 is not connected to terminal 91.

5. First Operation

Make sure that all mechanical and electrical connections are made properly.

Switch on the power supply. The LED “OK” will flash green.

After the power up sequence the display shows the preselected values (ex factory: “FLOW” and “BATCH”)

Switch on the flow. The value indicated in the display should be positive.

In case of an error the LED “ERR” will flash red.

As soon as the TCM has reached the operating temperature, make the zero point:

- Switch off the flow
- Wait until the flow through the TCM is zero
- Start the zero offset calibration in the “ZERO OFFSET” menu
- Wait until the offset procedure is finished
- Switch on the flow again

The display can be altered by pressing the pushbutton “Display”.

The internal device status can be viewed by pressing the pushbutton “Info”.

If the function is activated, the BATCH reading can be reset to zero by pressing the pushbutton “Reset”.

To open the control menu press button “P” for three seconds.

5.1.1. CONTROL Menu

In the “CONTROL“ menu all configurations can be made. This includes configuration of the analog and digital outputs, customizing the display and other settings.

The menu itself is self-explaining; the function of the softkeys is indicated in the display above the pushbuttons.

To enter the “CONTROL“ menu press the pushbutton “P” for three seconds.

If a global access code is set, the “CONTROL“ menu is completely locked.

With no global access code the submenu “DISPLAY” can be entered without a password as any changes in this submenu will not affect the operation of the TCM.

The submenus “ZERO OFFSET”, “SETUP”, “I/O-TEST” and “SERVICE” are password protected for avoiding unintentional changes of the operating parameters.

For “ZERO OFFSET”, “SETUP” and “I/O-TEST” the password is “2207”, for “SERVICE” refer to chapter 6 of the complete instruction manual (www.tricorflow.com).

Change the indicated number “2206” with the softkey “UP” to “2207” and confirm with “P”.

Select the desired submenu with the softkeys and confirm with “P”.

Every setting must be confirmed with “P” for storing the setting or with “EXIT” for exiting without storing.

For leaving the “SETUP” menu press “EXIT” until the TCE returns to the main level.

5.1.2. Using the magnet

The explosion-proof variants with the blue Ex d housings provide a magnet to be able to operate the pushbuttons without opening the display cover.

In hazardous, wet and dusty areas the display cover must not be opened to operate the pushbuttons.

Beside every pushbutton there is a hall sensor which can be operated via the magnet attached to the housing.

For operating the pushbuttons hold the magnet to the glass.

The best positions for operating the keys are:

| Pushbutton | Position |
|------------|------------------------------------|
| P | left upper edge of the yellow area |
| Reset | lower edge of the yellow area |
| Display | lower edge of the yellow area |
| Info | lower edge of the yellow area |



6. Contact

TRICOR web page

www.tricorflow.com

Sales

North and Sout America:

AW Lake Company
2440 W. Corporate Preserve Dr. #600
Oak Creek WI 53154
USA

Tel.: +1 414 574 4300
sales@aw-lake.com
www.aw-lake.com

China:

KEM Flow China
Rm. 430, JInYuan Building, No. 36 BeiyuanLu,
CN- Chaoyang District, Beijing 100012
P.R.CHINA

Tel.:+86 10 84929567 / +86 10 84929577
Fax:+86 10 52003739
info@kem-kueppers.com
www.kem-kueppers.cn

Southeast Asia:

KEM Küppers Elektromechanik GmbH
Representative Office (RO) Singapore
1003 Bukit Merah Central #06-32
Singapur 159836

UEN: T15RF0080G

Tel.: +65 6274 1130
info@kem-kueppers.com
www.kem-kueppers.cn

Europe:

KEM Küppers Elektromechanik GmbH
Liebigstraße 5
DE-85757 Karlsfeld
Germany

Tel.: +49 8131 593910
info@kem-kueppers.com
www.kem-kueppers.com

Manufacturer

KEM Küppers Elektromechanik GmbH

Liebigstraße 5
DE-85757 Karlsfeld
Germany

Tel.: +49 8131 593910
info@kem-kueppers.com
www.kem-kueppers.com

AW-Lake Company

2440 W. Corporate Preserve Dr. #600
Oak Creek WI 53154
USA

Tel.: +1 414 574 4300
sales@aw-lake.com
www.aw-lake.com

Original KEM/AWL document: TCM_E80_Q_EN_170116_E002
Copyright KEMAWL, Subject to change without notice